

ALL ACCESSORIES OPTIONAL

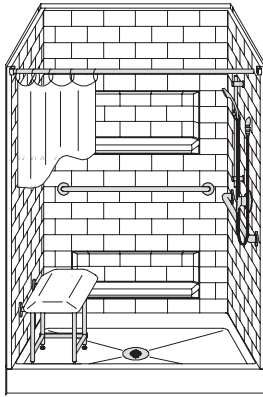

PERSPECTIVE VIEW - N.T.S.

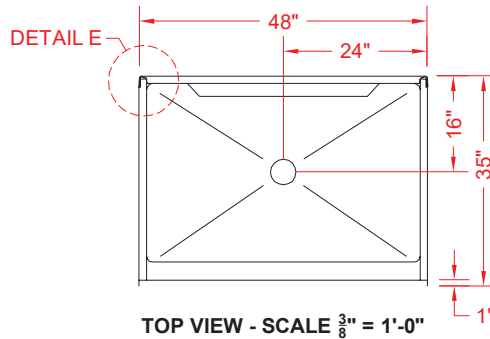

TOP VIEW - SCALE  $\frac{3}{8}'' = 1'-0''$

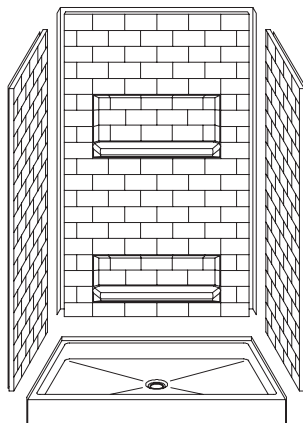

ASSEMBLY VIEW - N.T.S.

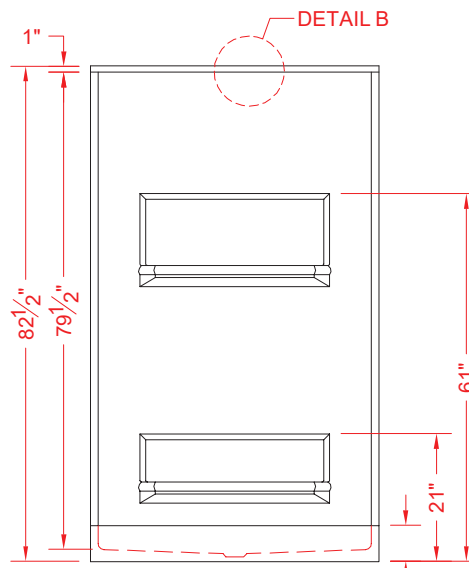

FRONT ELEVATION - SCALE:  $\frac{3}{8}'' = 1'-0''$

### Features:

- Molded, four-piece gelcoat/fiberglass shower module
- "Subway Tile" wall finish, white (standard)
- Integral full wood backing for strength and unlimited accessory placement
- Easy in-place installation from the front
- The authentic look of ceramic tile without the grout

\* - SEE BACK FOR DETAIL SECTIONS

### PRODUCT SPECIFICATIONS:

- Multi-piece shower module shall be constructed of gelcoat/fiberglass with full integral plywood backing in the walls
- Door opening: 45-3/8" x 75-3/8"
- Rough-In: Stud opening +1/4" -0" Nominal Dimensions.
- C.S.I. FORMAT SPECIFICATION TEXT AVAILABLE

### PRODUCT INFORMATION:

- Accessories: Polished chrome/satin stainless standard, others available.
- Colors: White as standard, others to match any major fixture manufacturer, also available with sprayable solid surface in many colors

### ACCESSORIES:

#### INSTALLED BY OTHERS:

- Grab bar
- Seat, folding
- Mixing valve, pressure balanced, lever handle, pre-plumbed tee to supply elbow
- Curtain and rod
- No-caulk brass drain

### CODES:

- Designed and manufactured in compliance with the following standards and codes:
- A.N.S.I. Z124.2 Standards for Plastic Showers
- I.P.C. International Plumbing Code
- U.P.C. Uniform Plumbing Code

### NOTICE OF LIMITATION:



Architectural Products for Barrier Free Living

www.barrierfree.org

(877) 717-7027

We reserve the right to make revisions without notice in the design of fixtures or in packaging unless this right has specifically been waived at the time the order is accepted.

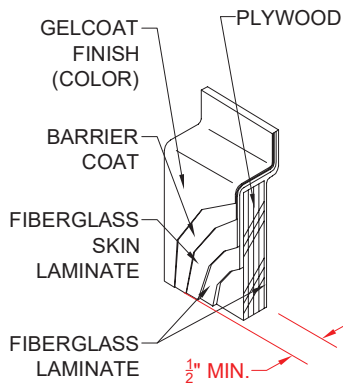

**DETAIL B - SCALE: 3" = 1'-0"**  
**WALL SECTION DETAIL**

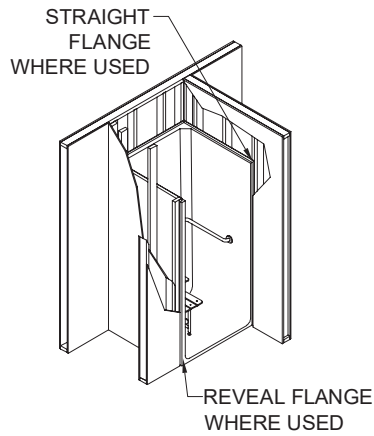

**DETAIL C - SCALE: NTS**  
**TYPICAL FRAMING**

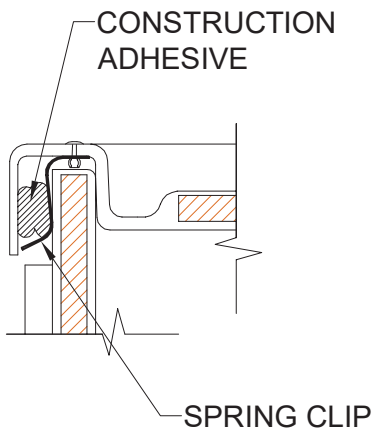

**DETAIL E - SCALE: NTS**  
**WALL JOINT DETAIL**