

MODEL: 5LES6333A75B*

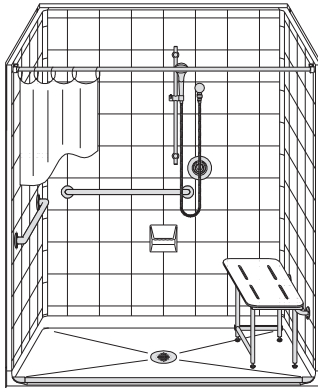

ALL ACCESSORIES OPTIONAL



PERSPECTIVE VIEW - N.T.S.

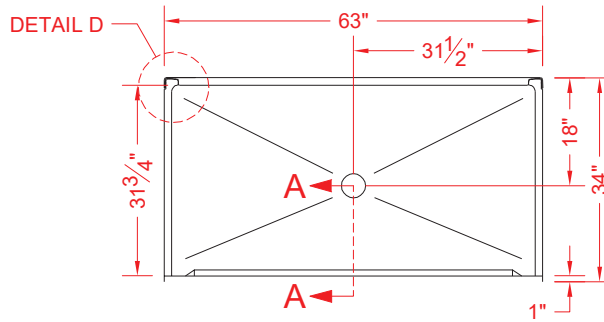

TOP VIEW - SCALE $\frac{3}{8}$ " = 1'-0"

Features:

- ADA compliant multi piece roll-in shower
- Available in various threshold heights
- Molded, five piece gelcoat/fiberglass shower module
- "Eight Inch Tile" wall finish, white (standard)
- Integral full wood backing for strength and unlimited accessory placement
- On all threshold heights 1-1/2" or taller, no mud set is required
- On all threshold heights 1-1/4" or shorter, no mud set is required and an anchoring adhesive kit is supplied

*OTHER THRESHOLD HEIGHTS AVAILABLE UPON REQUEST

| | UNIT HEIGHT | THRESHOLD HEIGHT |
|--------------|-------------|------------------|
| MODEL # | Y | Z* |
| 5LES6333A75B | 81-1/4" | 3/4" MIN. |
| 5LES6333A2B | 82-1/2" | 2" MAX. |

* - SEE BACK FOR DETAIL SECTIONS

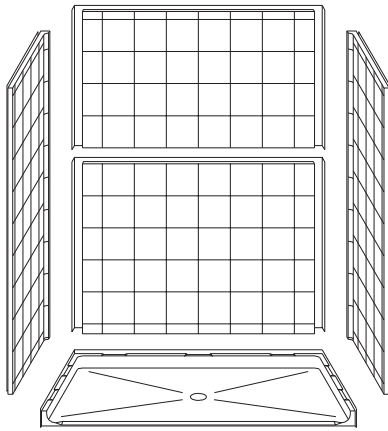

ASSEMBLY VIEW - N.T.S.

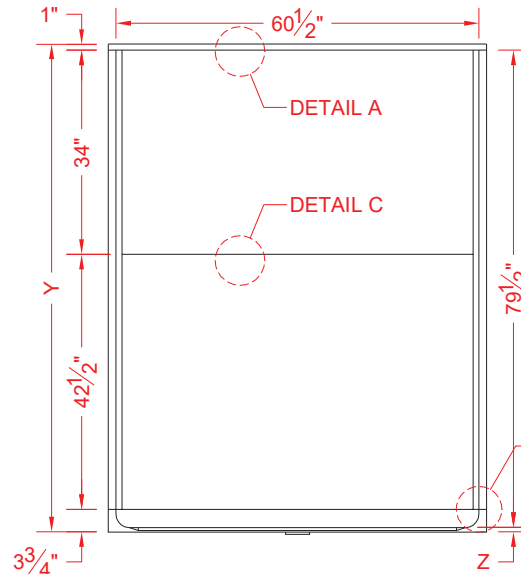

FRONT ELEVATION - SCALE: $\frac{3}{8}$ " = 1'-0"

PRODUCT SPECIFICATIONS:

- Multi piece shower module shall be constructed of gelcoat/fiberglass with full integral plywood backing
- Rough-In: Stud opening +1/4" -0" Nominal Dimensions.

C.S.I. FORMAT SPECIFICATION TEXT AVAILABLE

PRODUCT INFORMATION:

- Accessories: Factory installed, unless prone to damage during installation/shipping. Polished chrome/satin stainless standard, others available.
- Colors: White as standard, others to match any major fixture manufacturer, also available with sprayable solid surface in many colors
- Custom curb heights, other than shown, are available (between min. and max.)

ACCESSORIES:

INSTALLED BY OTHERS:

- Grab bar
- Seat, folding
- Mixing valve, pressure balanced, lever handle, preplumbed tree to supply elbow
- Curtain and rod
- T-Shaped Rubber WaterStopper Kit
- Semi-permanent Threshold Adaptor
- Caulkless drain

CODES:

- Designed and manufactured in compliance with the following standards and codes:
- A.N.S.I. Z124.2 Standards for Plastic Showers
 - I.P.C. International Plumbing Code
 - U.P.C. Uniform Plumbing Code
 - A.D.A. Accessibility Guidelines for Buildings and Facilities
 - A.N.S.I. A117.1 Accessible and Usable Buildings and Facilities

NOTICE OF LIMITATION:

- Adhere to floor as required



Architectural Products for Barrier Free Living

www.barrierfree.org (877) 717-7027

We reserve the right to make revisions without notice in the design of fixtures or in packaging unless this right has specifically been waived at the time the order is accepted.

5LES6333A75B

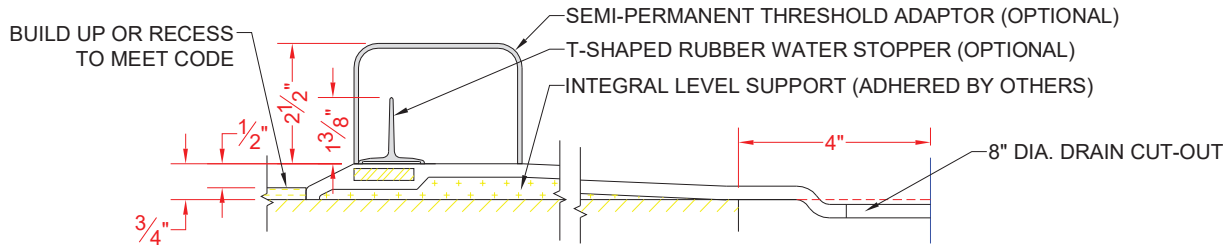

SECTION A-A - SCALE: 3" = 1'-0"

5LES6333A2B

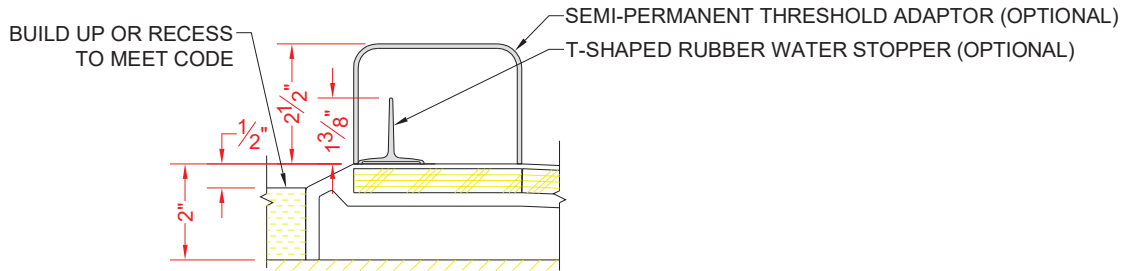

SECTION A-A - SCALE: 3" = 1'-0"

****OTHER THRESHOLD HEIGHTS AVAILABLE UPON REQUEST****

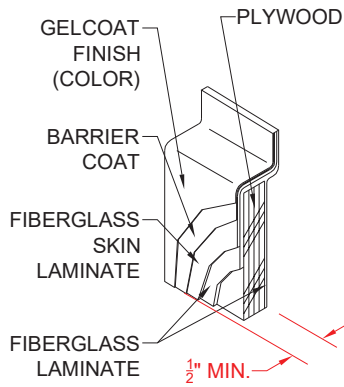

DETAIL A - SCALE: N.T.S.
WALL SECTION DETAIL

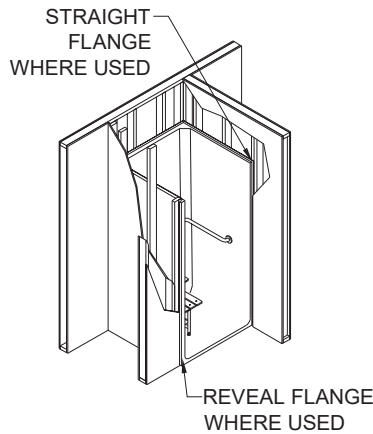

DETAIL B - SCALE: N.T.S.
TYPICAL FRAMING

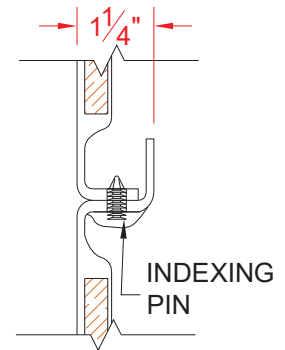

DETAIL C - SCALE: N.T.S.
BACK WALL JOINT DETAIL

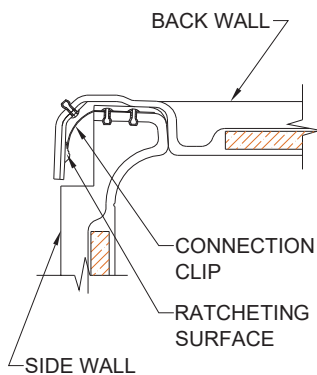

DETAIL D - SCALE: N.T.S.
WALL JOINT DETAIL

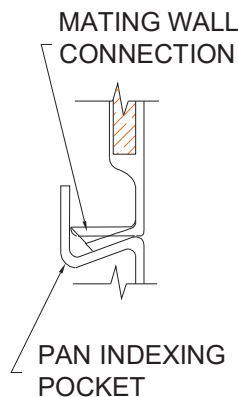

DETAIL E - SCALE: N.T.S.
PAN JOINT DETAIL