

MODEL: 5LRS6030BSD25T

REMODELER

ALL ACCESSORIES OPTIONAL

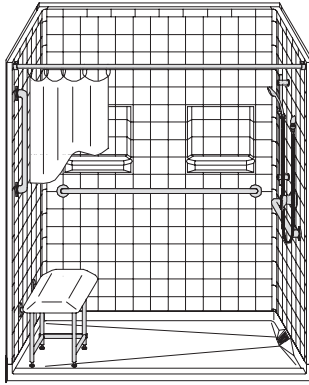

PERSPECTIVE VIEW - N.T.S.
MODEL SHOWN HERE AS:
RIGHT HAND

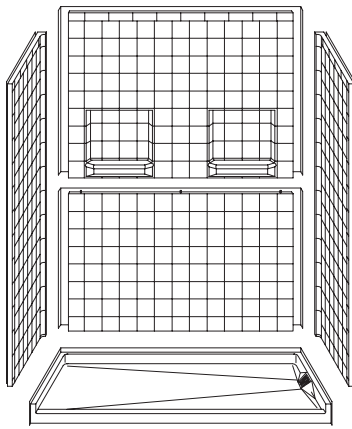

ASSEMBLY VIEW - N.T.S.

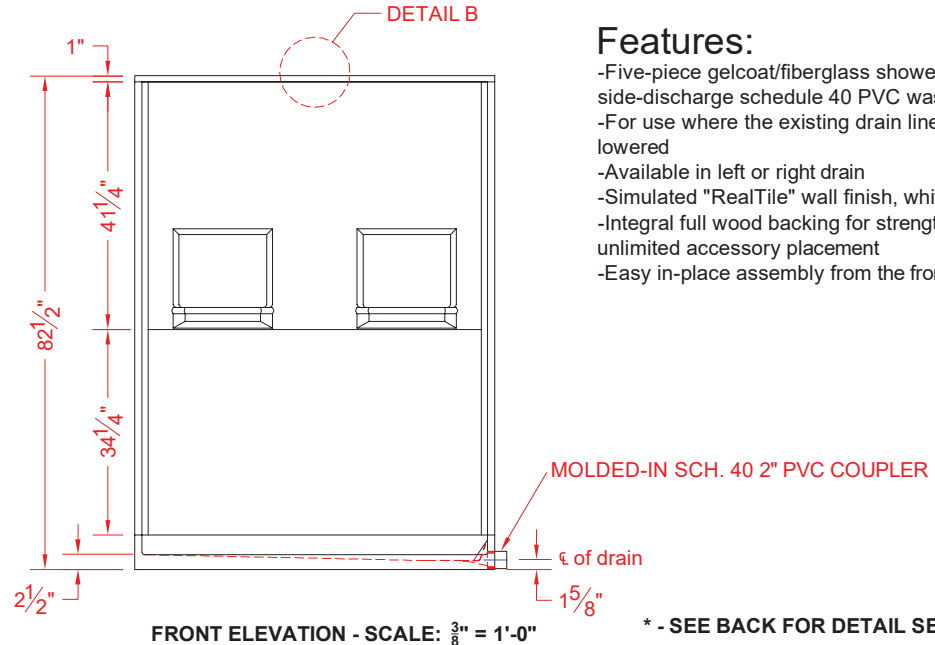
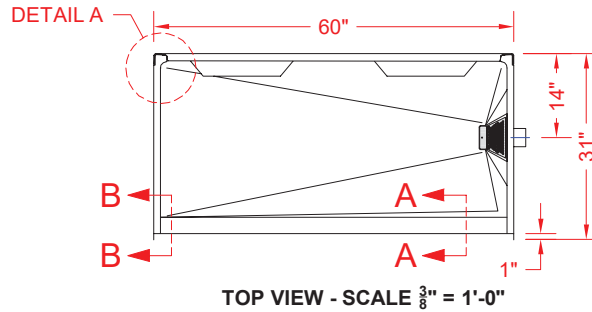

Features:

- Five-piece gelcoat/fiberglass shower module with side-discharge schedule 40 PVC waste outlet
- For use where the existing drain line cannot be lowered
- Available in left or right drain
- Simulated "RealTile" wall finish, white (standard)
- Integral full wood backing for strength and unlimited accessory placement
- Easy in-place assembly from the front

PRODUCT SPECIFICATIONS:

- Multi-piece shower module shall be constructed of gelcoat/fiberglass with full integral plywood backing
- Rough-In: Stud opening +1/4" -0" Nominal Dimensions.

C.S.I. FORMAT SPECIFICATION TEXT AVAILABLE

PRODUCT INFORMATION:

- Accessories: Polished chrome/satin stainless standard, others available.
- Colors: White as standard, others to match any major fixture manufacturer, also available with sprayable solid surface in many colors
- Custom curb heights, other than shown, are available (between min. and max.)

ACCESSORIES:

INSTALLED BY OTHERS:

- Grab bar
- Seat, folding
- Mixing valve, pressure-balancing, lever handle, pre-plumbed tee to supply elbow
- Curtain and rod
- T-shaped rubber WaterStopper kit
- Semi-permanent threshold adaptor
- Stainless steel drain screen (included)

CODES:

Designed and manufactured in compliance with the following standards and codes:

- A.N.S.I. Z124.2 Standards for Plastic Showers

NOTICE OF LIMITATION:



Architectural Products for Barrier Free Living

www.barrierfree.org

(877) 717-7027

We reserve the right to make revisions without notice in the design of fixtures or in packaging unless this right has specifically been waived at the time the order is accepted.

5LRS6030BSD25T

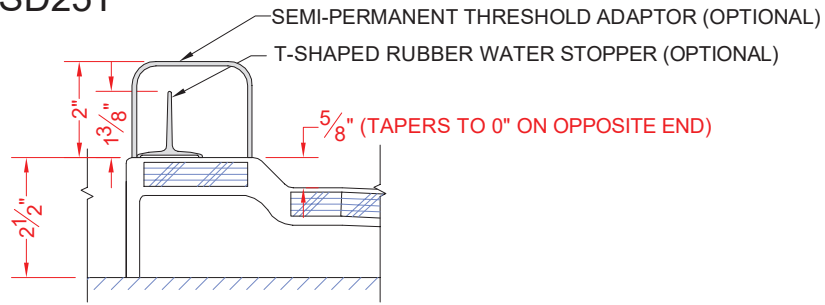

SECTION A-A - SCALE: 3" = 1'-0"

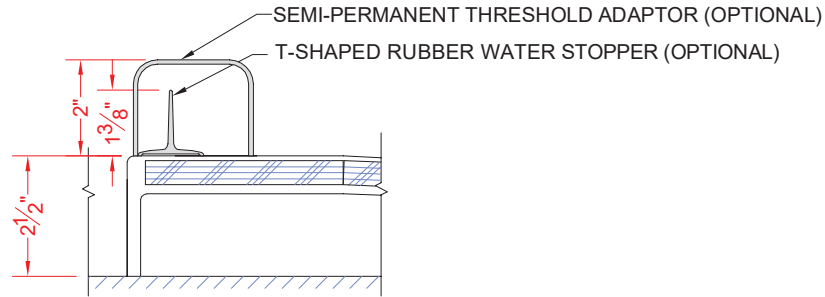

SECTION B-B - SCALE: 3" = 1'-0"

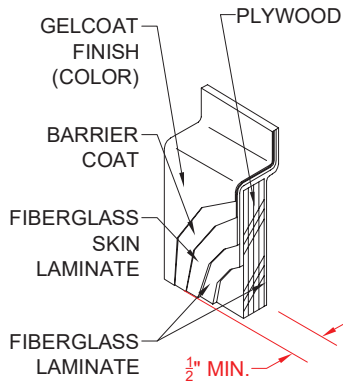

DETAIL B - SCALE: 3" = 1'-0"
WALL SECTION DETAIL

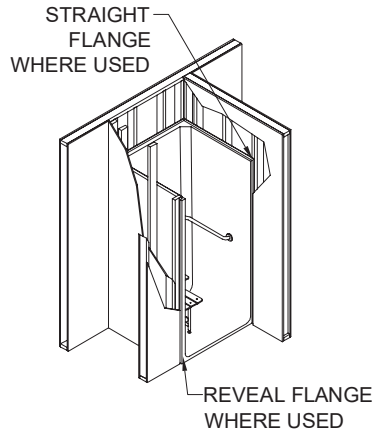

DETAIL C - SCALE: NTS
TYPICAL FRAMING

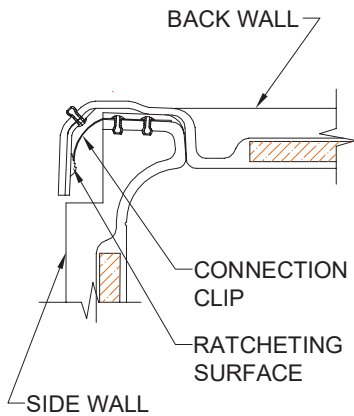

DETAIL A - SCALE: NTS
WALL JOINT DETAIL