

Flip-up Grab Bar with Leg

with "All Stainless Steel Friction Hinge"

Configuration: 97

Flip-up
With Leg

Application Use:

Architectural

Commercial

Institutional

Residential

Specifications

Manufactured by ELCOMA from 1.25" & 1.5" 18 gauge, type 304 stainless steel, with an all stainless steel mounting hinge bracket. The smooth motion Friction hinge can be easily raised and lowered from a wheelchair with little effort. The friction holds the bar just past 90 deg when in the up position allowing it to be safely out of the way when not in use. ELCOMA Flip-up grab bars are designed, built, and tested to withstand 250lbs. (113kgs) of vertical load when properly installed.* This exceeds HUD, FHA,VA, ADA, ANSI and other federal, provincial, and local codes. *Grab Bars can only be as strong as what they are mounted to. It is imperative when installing any safety product to consult with a qualified contractor to insure you have sufficient backing.



Custom sizes are available to suit special requirements.

Elcoma manufactures a standard 42" & 54" loop with custom lengths available upon request. Flip-up safety rails are designed to be used for vertical load in the down position only.

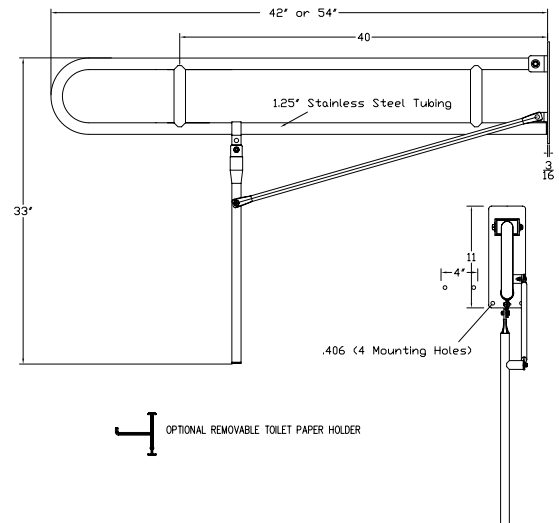

Bar Diameter:	1.25"
Bar Grip:	Smooth, Peened, Knurled, Shur-Grip
Wall Bracket:	Satin Finish Stainless Steel
Standard Finishes:	Satin Finish
Custom Finishes:	N/A
Toilet paper options:	Removable
Carrier Options:	N/A