

MODEL: P3838B5B.V2*

ALL ACCESSORIES OPTIONAL

BARRIER FREE

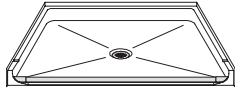

PERSPECTIVE VIEW - N.T.S.

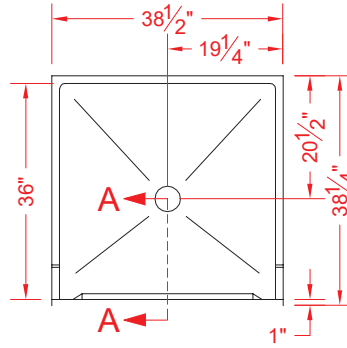

TOP VIEW - SCALE $\frac{3}{8}'' = 1'-0''$



Features:

- Molded, single-piece gelcoat/fiberglass shower pan
- Available in various threshold heights
- On all threshold heights 1-1/2" or taller, no mud set is required
- On all threshold heights 1-1/4" or shorter, no mud set is required and an anchoring adhesive kit is supplied

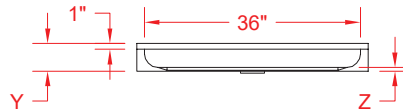

FRONT ELEVATION - SCALE: $\frac{3}{8}'' = 1'-0''$

*OTHER THRESHOLD HEIGHTS AVAILABLE UPON REQUEST

MODEL #	UNIT	THRESHOLD
	HEIGHT	HEIGHT
P3838B5B.V2	Y	Z*
P3838B5B.V2	4-5/8"	5/8" MIN
P3838B2B.V2	6"	2" MAX

* - SEE BACK FOR DETAIL SECTIONS

PRODUCT SPECIFICATIONS:

- Single-piece shower pan shall be constructed of gelcoat/fiberglass
- Rough-In: Stud opening +1/4" -0" Nominal Dimensions.

C.S.I. FORMAT SPECIFICATION TEXT AVAILABLE

PRODUCT INFORMATION:

- Colors: White as standard, others to match any major fixture manufacturer, also available with sprayable solid surface in many colors
- Custom curb heights, other than shown, are available (between min. and max.)

ACCESSORIES:

- INSTALLED BY OTHERS:
- T-shaped rubber WaterStopper kit
 - Semi-permanent threshold adaptor
 - No-caulk brass drain

CODES:

- Designed and manufactured in compliance with the following standards and codes:
- ANSI Z124.2 Standards for Plastic Showers
 - IPC International Plumbing Code
 - UPC Uniform Plumbing Code

NOTICE OF LIMITATION:

- Adhere to floor as required



Architectural Products for Barrier Free Living

www.barrierfree.org (877) 717-7027

We reserve the right to make revisions without notice in the design of fixtures or in packaging unless this right has specifically been waived at the time the order is accepted.

□ P3838B5B.V2

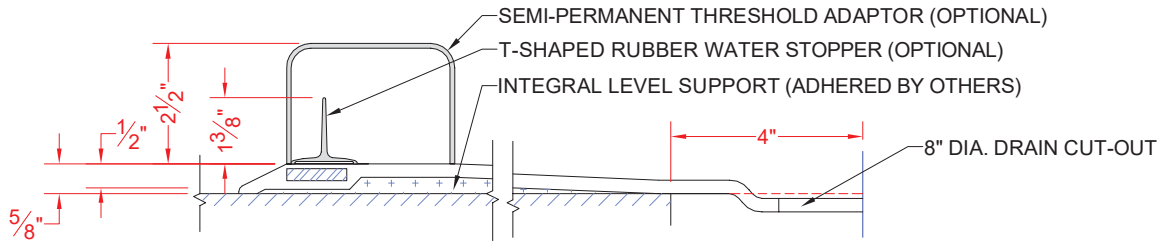

SECTION A-A - SCALE: 3" = 1'-0"

□ P3838B2B.V2

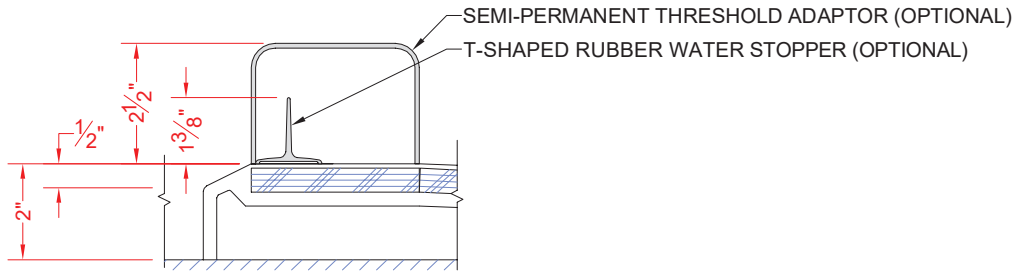

SECTION A-A - SCALE: 3" = 1'-0"

****OTHER THRESHOLD HEIGHTS AVAILABLE UPON REQUEST****

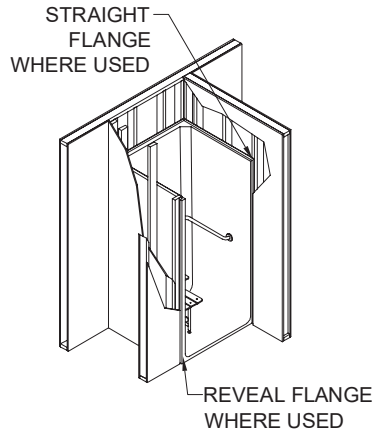

TYPICAL FRAMING