

# MODEL: P4038A5B\*

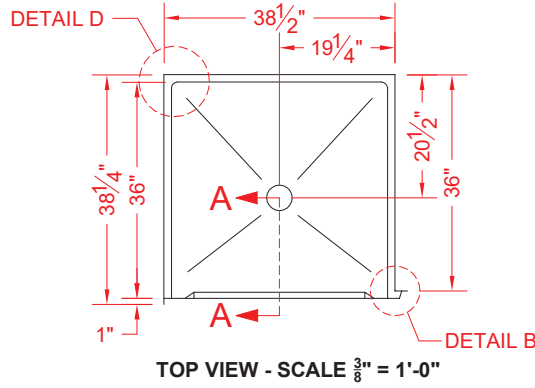

SEE OVER

ALL ACCESSORIES OPTIONAL



PERSPECTIVE VIEW - N.T.S.  
LEFT HAND PLUMBING MODEL  
SHOWN

## Features:

- ADA compliant multi piece transfer shower
- Available in various threshold heights
- Molded gelcoat/fiberglass shower pan
- On all threshold heights 1-1/2" or taller, no mud set is required
- On all threshold heights 1-1/4" or shorter, no mud set is required and an anchoring adhesive kit is supplied

## \*OTHER THRESHOLD HEIGHTS AVAILABLE UPON REQUEST

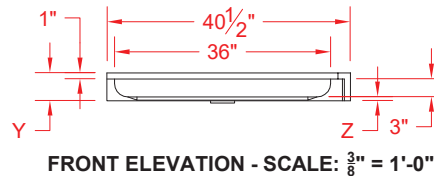

	UNIT HEIGHT	THRESHOLD HEIGHT
MODEL #	Y	Z*
P4038A5B	4-5/8"	5/8" MIN.
P4038A2B	6"	2" MAX.

\* - SEE BACK FOR DETAIL SECTIONS

## PRODUCT SPECIFICATIONS:

- One piece shower pan shall be constructed of gelcoat/fiberglass
- Rough-In: Stud opening +1/4" -0" Nominal Dimensions.

C.S.I. FORMAT SPECIFICATION TEXT AVAILABLE

## PRODUCT INFORMATION:

- Accessories: Factory installed, unless prone to damage during installation/shipping. Polished chrome/satin stainless standard, others available.
- Colors: White as standard, others to match any major fixture manufacturer, also available with sprayable solid surface in many colors
- Custom curb heights, other than shown, are available (between min. and max.)

## ACCESSORIES:

### INSTALLED BY OTHERS:

- T-Shaped Rubber WaterStopper Kit
- Semi-permanent Threshold Adaptor
- Caulkless drain

## CODES:

Designed and manufactured in compliance with the following standards and codes:

- A.N.S.I. Z124.2 Standards for Plastic Showers
- I.P.C. International Plumbing Code
- U.P.C. Uniform Plumbing Code
- A.D.A. Accessibility Guidelines for Buildings and Facilities
- A.N.S.I. A117.1 Accessible and Usable Buildings and Facilities

## NOTICE OF LIMITATION:

- Adhere to floor as required



Architectural Products for Barrier Free Living

www.barrierfree.org

(877) 717-7027

We reserve the right to make revisions without notice in the design of fixtures or in packaging unless this right has specifically been waived at the time the order is accepted.

**P4038A5B**

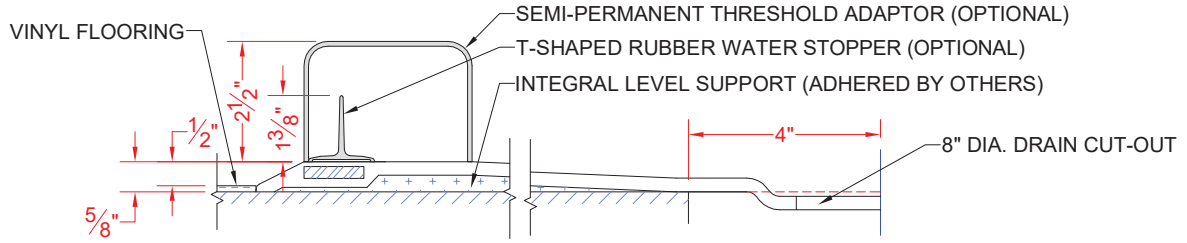

**SECTION A-A - SCALE: 3" = 1'-0"**

**P4038A2B**

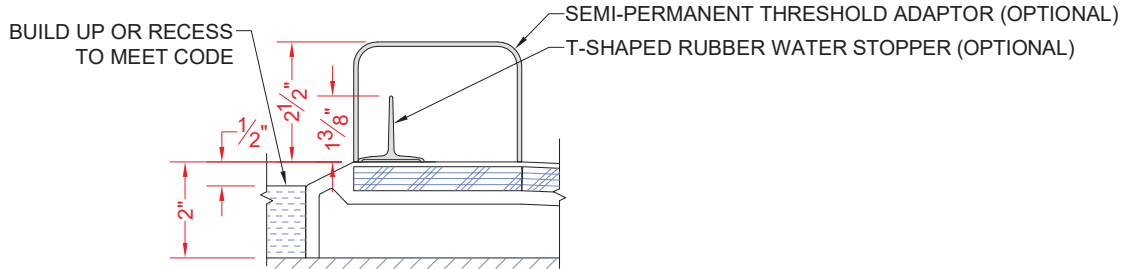

**SECTION A-A - SCALE: 3" = 1'-0"**

**\*\*OTHER THRESHOLD HEIGHTS AVAILABLE UPON REQUEST\*\***

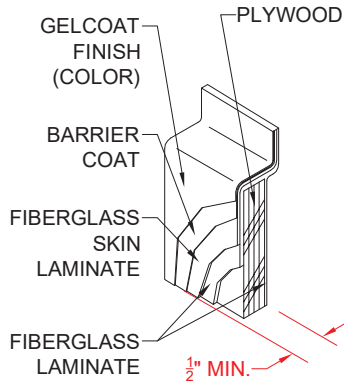

**DETAIL A - SCALE: N.T.S.  
WALL SECTION DETAIL**

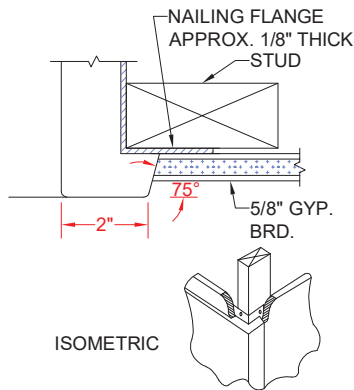

**DETAIL B - SCALE: NTS  
REVEAL DETAIL**

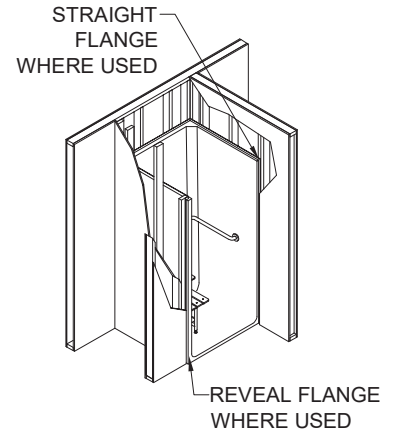

**TYPICAL FRAMING**