

MODEL: P4834B5T*

ALL ACCESSORIES OPTIONAL

BARRIER FREE

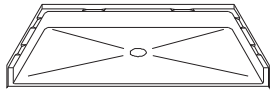

PERSPECTIVE VIEW - N.T.S.
MODEL SHOWN HERE AS:

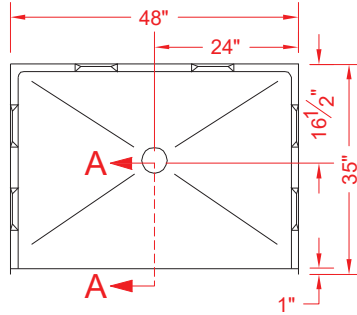

TOP VIEW - SCALE $\frac{3}{8}'' = 1'-0''$



Features:

- Molded, one piece gelcoat/fiberglass shower pan
- Available in various threshold heights
- On all threshold, heights 1-1/2" or taller, no mud set is required
- On all Threshold, heights 1-1/4" or shorter, no mud set is required, but an epoxy adhesive kit is supplied

*OTHER THRESHOLD HEIGHTS AVAILABLE UPON REQUEST

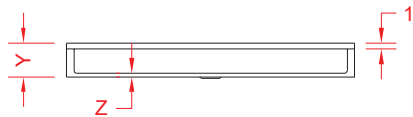

FRONT ELEVATION - SCALE: $\frac{3}{8}'' = 1'-0''$

MODEL #	UNIT HEIGHT Y	THRESHOLD HEIGHT Z*
P4834B5T	5-5/8"	5/8" MIN.
P4834B2T	7"	2" MAX.

* - SEE BACK FOR DETAIL SECTIONS

PRODUCT SPECIFICATIONS:

- One piece shower pan shall be constructed of gelcoat/fiberglass
- Rough-In: Stud opening + 1/4"-0" Nominal Dimensions.

C.S.I. FORMAT SPECIFICATION TEXT AVAILABLE

PRODUCT INFORMATION:

- Colors: White as standard, others to match any major fixture manufacturer, also available with sprayable solid surface in many colors

ACCESSORIES:

INSTALLED BY OTHERS:

- Collapsible Rubber Water Retainer
- Semi-permanent Threshold Adaptor
- Caulkless drain

CODES:

- Designed and manufactured in compliance with the following standards and codes:
- A.N.S.I. Z124.2 Standards for Plastic Showers
 - I.P.C. International Plumbing Code
 - U.P.C. Uniform Plumbing Code

NOTICE OF LIMITATION:



Architectural Products for Barrier Free Living

www.barrierfree.org

(877) 717-7027

We reserve the right to make revisions without notice in the design of fixtures or in packaging unless this right has specifically been waived at the time the order is accepted.

P4834B5T

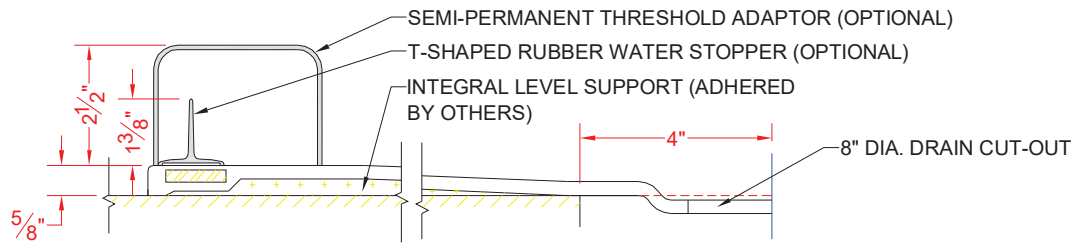

SECTION A-A - SCALE: 3" = 1'-0"

P4834B2T

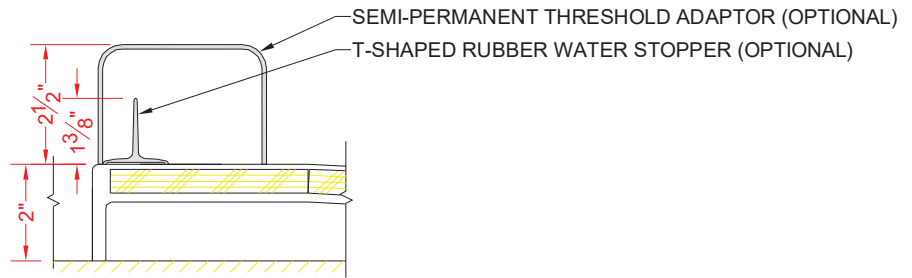

SECTION A-A - SCALE: 3" = 1'-0"

****OTHER THRESHOLD HEIGHTS AVAILABLE UPON REQUEST****