

MODEL: P6036E1B*

ALL ACCESSORIES OPTIONAL

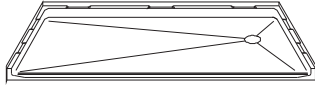

BARRIER FREE



PERSPECTIVE VIEW - N.T.S.
MODEL SHOWN HERE AS:

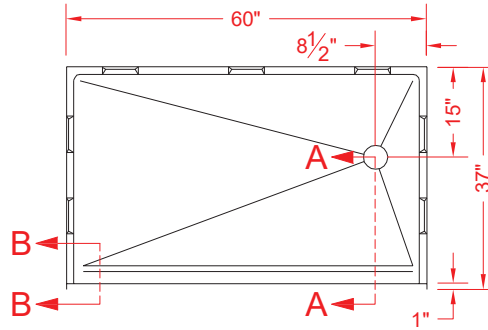

TOP VIEW - SCALE $\frac{3}{8}'' = 1'-0''$



Features:

- Molded, one piece gelcoat/fiberglass shower pan
- Available in various threshold heights
- On all threshold heights 1-1/2" or taller, no mud set is required
- On all threshold heights 1-1/4" or shorter, no mud set is required and an anchoring adhesive kit is supplied

*OTHER THRESHOLD HEIGHTS AVAILABLE UPON REQUEST

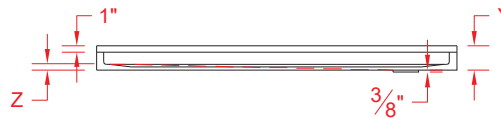

FRONT ELEVATION - SCALE: $\frac{3}{8}'' = 1'-0''$

MODEL #	UNIT HEIGHT	THRESHOLD HEIGHT
P6036E1B	Y	Z*
P6036E1B	4"	1" MIN
P6036E2B	5"	2" MAX

* - SEE BACK FOR DETAIL SECTIONS

PRODUCT SPECIFICATIONS:

- One piece shower pan shall be constructed of gelcoat/fiberglass
- Rough-In: Stud opening +1/4" -0" Nominal Dimensions.

C.S.I. FORMAT SPECIFICATION TEXT AVAILABLE

PRODUCT INFORMATION:

- Colors: White as standard, others to match any major fixture manufacturer, also available with sprayable solid surface in many colors

ACCESSORIES:

- INSTALLED BY OTHERS:
- T-Shaped Rubber WaterStopper Kit
 - Semi-permanent Threshold Adapter
 - Caulkless drain

CODES:

- Designed and manufactured in compliance with the following standards and codes:
- A.N.S.I. Z124.2 Standards for Plastic Showers
 - I.P.C. International Plumbing Code
 - U.P.C. Uniform Plumbing Code

NOTICE OF LIMITATION:

- Indexing pockets may require tile/other walls to be shimmed out to cover



www.barrierfree.org (877) 717-7027

We reserve the right to make revisions without notice in the design of fixtures or in packaging unless this right has specifically been waived at the time the order is accepted.

 P6036E1B

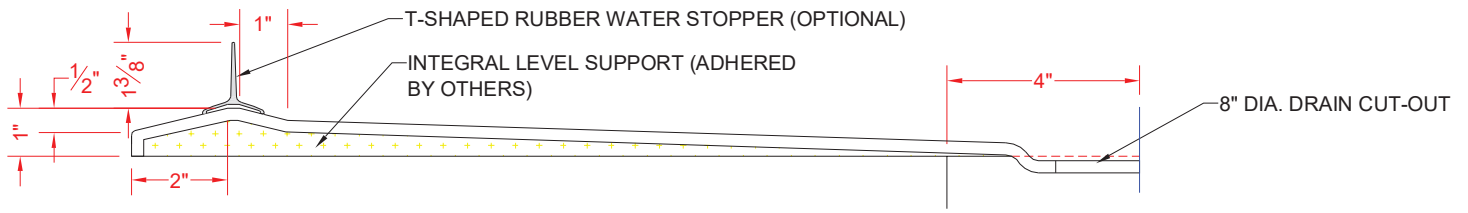

SECTION A-A - SCALE: 3" = 1'-0"

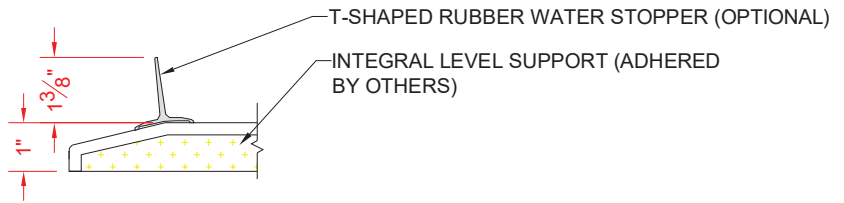

SECTION B-B - SCALE: 3" = 1'-0"

****OTHER THRESHOLD HEIGHTS AVAILABLE UPON REQUEST****