

MODEL: PC4848B1B.V2*

BARRIER FREE

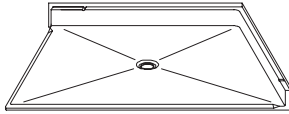

PERSPECTIVE VIEW - N.T.S.
MODEL SHOWN HERE AS:

ALL ACCESSORIES OPTIONAL

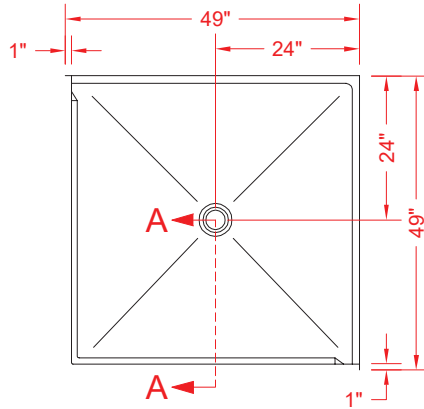

TOP VIEW - SCALE $\frac{3}{8}'' = 1'-0''$



Features:

- Molded, single-piece gelcoat/fiberglass shower pan
- Available in various threshold heights
- On all threshold, heights 1-1/2" or taller, no mud set is required
- On all Threshold, heights 1-1/4" or shorter, no mud set is required, but an epoxy adhesive kit is supplied

*OTHER THRESHOLD HEIGHTS AVAILABLE UPON REQUEST

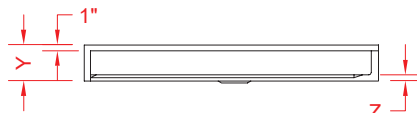

FRONT ELEVATION - SCALE: $\frac{3}{8}'' = 1'-0''$

	UNIT HEIGHT	THRESHOLD HEIGHT
MODEL #	Y	Z*
PC4848B1B.V2	6"	1" MIN
PC4848B2B.V2	7"	2" MAX

* - SEE BACK FOR DETAIL SECTIONS

PRODUCT SPECIFICATIONS:

- Single-piece shower pan shall be constructed of gelcoat/fiberglass
- Rough-In: Stud opening + 1/4"-0" Nominal Dimensions.

C.S.I. FORMAT SPECIFICATION TEXT AVAILABLE

PRODUCT INFORMATION:

- Colors: White as standard, others to match any major fixture manufacturer, also available with sprayable solid surface in many colors

ACCESSORIES:

INSTALLED BY OTHERS:

- T-shaped rubber WaterStopper kit
- Semi-permanent threshold adaptor
- No-caulk brass drain

CODES:

- Designed and manufactured in compliance with the following standards and codes:
- ANSI Z124.2 Standards for Plastic Showers
 - IPC International Plumbing Code
 - UPC Uniform Plumbing Code

NOTICE OF LIMITATION:



Architectural Products for Barrier Free Living

www.barrierfree.org

(877) 717-7027

We reserve the right to make revisions without notice in the design of fixtures or in packaging unless this right has specifically been waived at the time the order is accepted.

□ PC4848B1B.V2

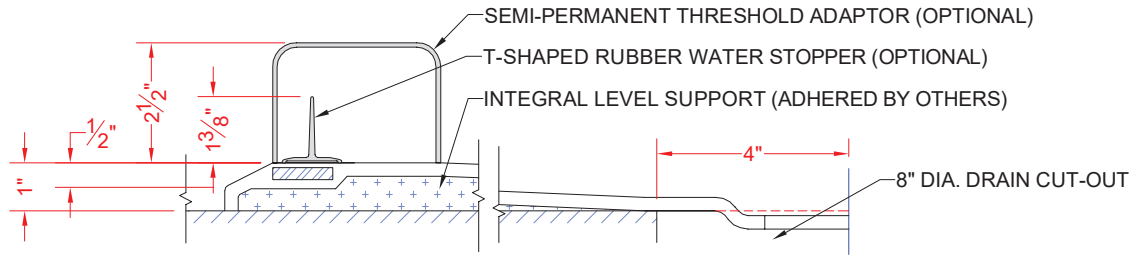

SECTION A-A - SCALE: 3" = 1'-0"

□ PC4848B2B.V2

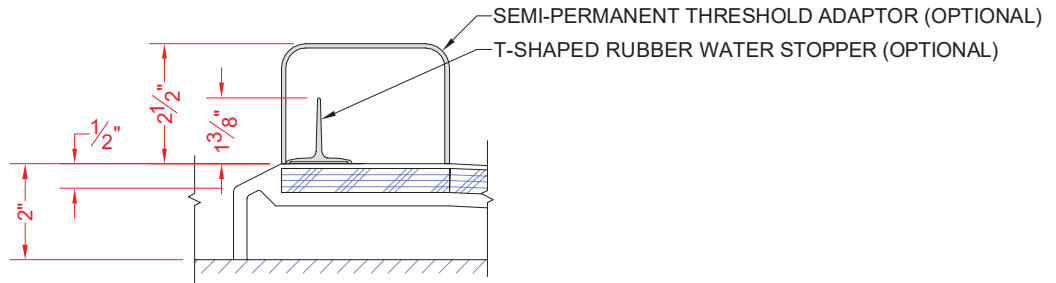

SECTION A-A - SCALE: 3" = 1'-0"

****OTHER THRESHOLD HEIGHTS AVAILABLE UPON REQUEST****