

Flip-up Safety Rail with "Locking Hinge"

Optional toilet paper holder, available as a removable (shown) or fixed item.

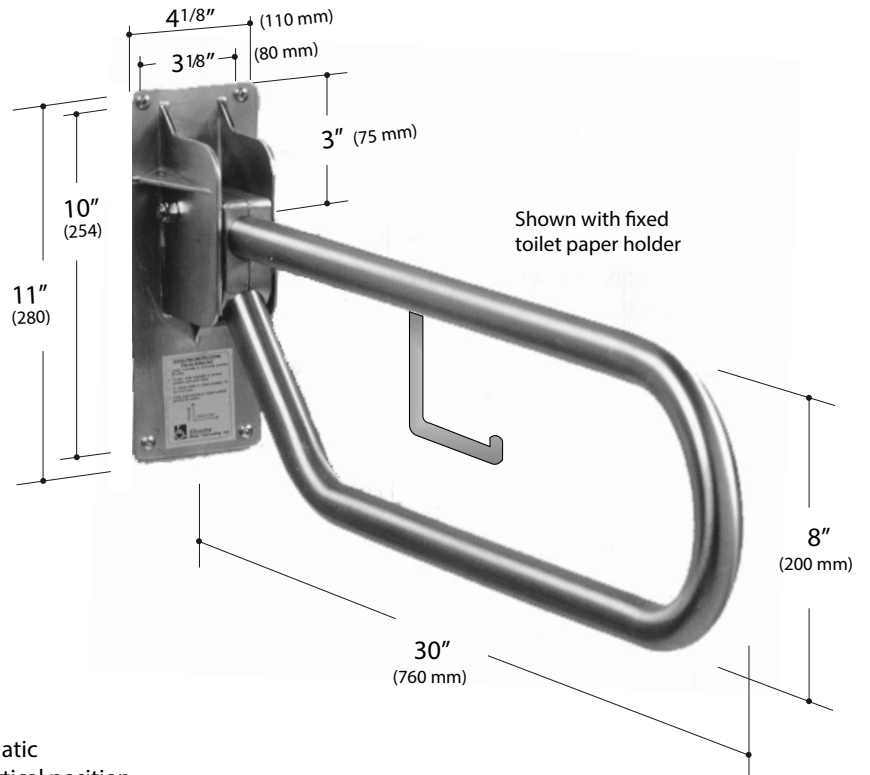
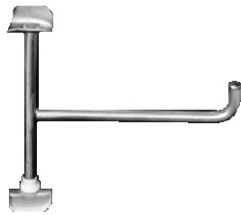

FEATURES:

The ELCOMA "Locking Hinge" flip-up features an automatic locking system that swings freely and locks up in the vertical position.

Alloy and stainless steel construction. The hinge bracket is made from heavy duty die cast alloy. Available with a brushed metal finish or painted in White or Almond.

ELCOMA offers 1.25" (32 mm) diameter Flip-ups with choice in bar material, finish, grip and colour. The bars can be made of 18 gauge, Type 304 stainless steel or 18 ga. mild steel for chrome plated or painted finish. Grip options include Peened, Knurled or patterned Shur-Grip. Bars can be satin finished s.s., painted s.s., satin or painted Shur Grip s.s. or mild steel with chrome plated or painted finish.

Custom lengths are available to suit special requirements.

More than 25 designer colors are available on special request.

To be used in the down position for verticle assistance only.

ELCOMA safety flip-up rails have been designed and tested to withstand more than 250 lbs. (113 kg.) of downward force when properly installed.

Installation should be completed by a Qualified tradesman to assure that the unit will support the load for which it is intended.

